

lubrication systems

ilc



EAM System

Centralized Lubrication Systems
for Earthmoving, Agricultural and Municipal Vehicles

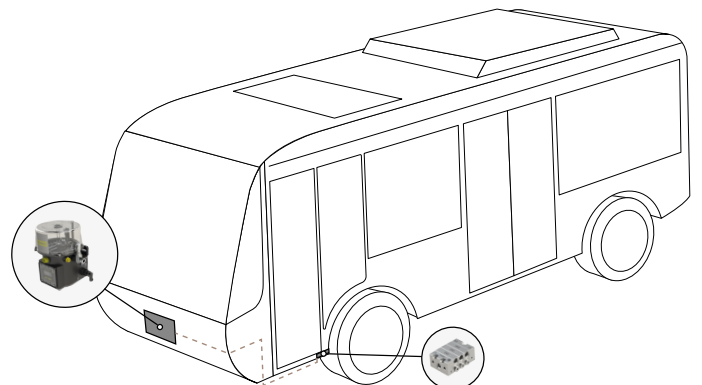
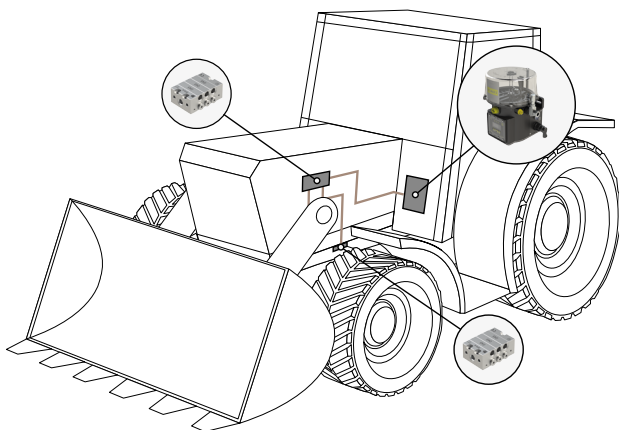
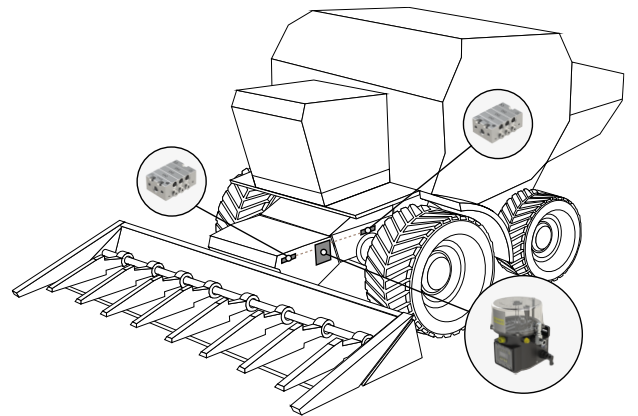

INDEX OF CONTENT

07.270.7	10	ILC MAX 4K	3
40.BMI.00	15	ILC MAX 4K	3
40.BMI.01	15	ILC MAX 4K 8-16 Kg	4
40.BMI.02	15	ILC MAX 4K 8-16 KG	4
45° Adapter M-F	20	ILC MAX 8-16 Kg	6
45.12-24.DC.CT	9	ILC MAX 8-16 KG	6
45.12-24.DC.PG.CT	9	ILC MAX Pumping Element	14
A51.1061003	10	Inlet / Outlet Fittings	16
A70.093526	10	Low Pressure Fittings	29
Brushes	29	Manual loading pump and adapter (Grease)	10
Cabine Push Button	22	MINI-MAX 3K	7
Check Valves	17	Mini-Max filling nipple	10
Clamps and Straps	19	Minimax Pumping Element	14
Connectors	19	Minimax Small Pumping Element	14
CX-1	26	PMU Pump	28
Divider Accessories	17	Point Fittings	20
DPL	13	Protections	19
Dpx Bracket	23	Pump Bracket	23
Elbow Adapter M-F	20	Push-In Fittings	16
Elbow Greasing Block 1/8"	21	Push-In Fittings with check valve	16
Elbow Greasing Block M10x1	21	Reservoir (4L)	28
Elektra	25	Straight Adaptor R 1/8 - G 1/8 F (h=60 mm)	20
Extension Pieces M-F	20	Transmission Kit	28
External Timer	27	Welding Protection	22
External Timer (12-24 V DC)	22	Z Bracket	23
Fittings	27		
Grease Nipples	22		
Greasing Block 1/8"	21		
Greasing Block M10x1	21		
High Pressure Fittings	29		
Hose fittings	18		
Hose fittings	27		
Hoses	18		
Hydra	24		
ILC MAX	5		

ILC MAX 4K

How to build the part number

Working in TIME and CYCLES

| 4K | . | 4 | . | 24DC | . | FCT | . | G |



A (Reservoir)		D (Timer)	
2	2 kg	CT	with timer
4	4 kg	ST	without timer
8	10 kg	DT	with datalog

B (Voltage)		E (Lubricant)	
12DC	12 V DC	G	Grease
24DC	24 V DC	O	Oil
		S	Soft Grease

C (Pumping Element)	
F	Fixed
R	Adjustable
X	No element

Dimensions

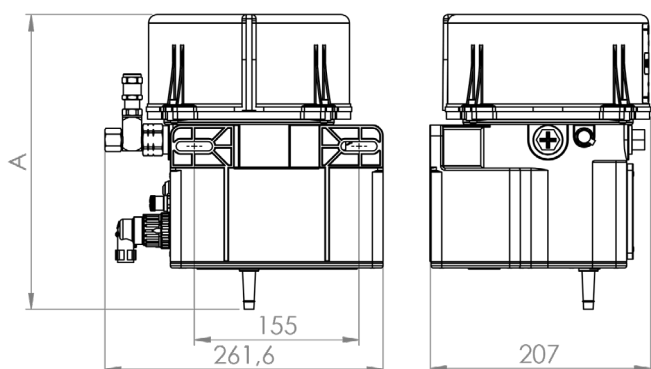

Cables

Length	5 Poles
5 m	40.CBL.5.05.AK
10 m	40.CBL.5.10.AK
15 m	40.CBL.5.15.AK

Outlet Fittings Ø 6 mm

FH.040.102	Elbow
FH.040.002	Straight

A (height)

Fixing Screws (order 2 of each one)

2 kg	277,60 mm
4 kg	349,60 mm
10 kg	543,10 mm

UNI5931-M8x30	Screw
UNI7473-M08	Nut
UNI1734-D08	Washer

ILC MAX 4K 8-16 Kg

How to build the part number

Working in TIME and CYCLES

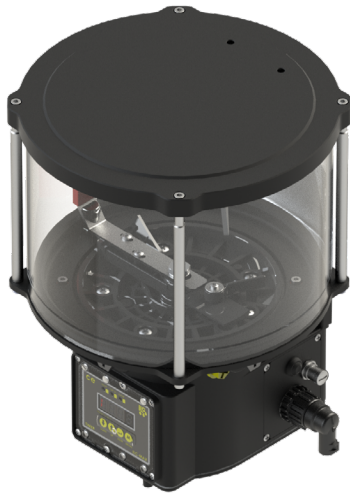
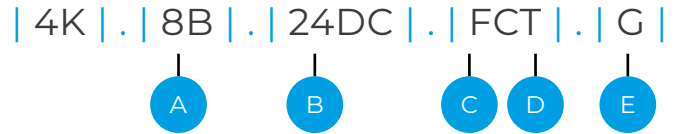

A (Reservoir) **D (Timer)**

8B	8 Kg	CT	with timer
16	16 Kg	ST	without timer
		DT	with datalog

B (Voltage) **E (Lubricant)**

12DC	12 V DC	G	Grease
24DC	24 V DC	O	Oil
		S	Soft Grease

C (Pumping Element)

F	Fixed
R	Adjustable
X	No element

Dimensions

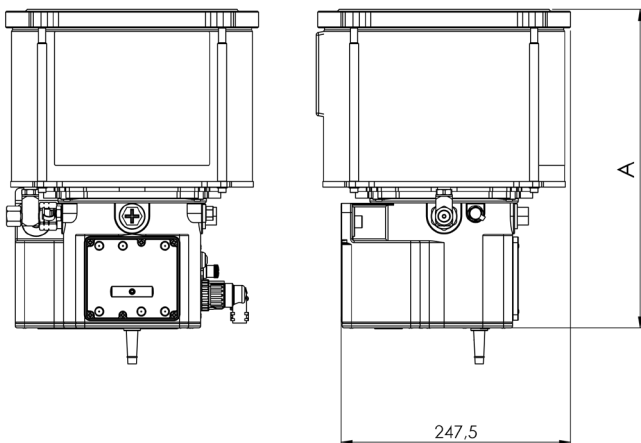

Cables

Length **5 Poles**

5 m	40.CBL.5.05.AK
10 m	40.CBL.5.10.AK
15 m	40.CBL.5.15.AK

Outlet Fittings Ø 6 mm

FH.040.102	Elbow
FH.040.002	Straight

A (height)

8 Kg	344,1 mm
16 Kg	519,6 mm

Fixing Screws (order 2 of each one)

UNI5931-M8x30	Screw
UNI7473-M08	Nut
UNI1734-D08	Washer

ILC MAX

How to build the part number

Working in TIME and ROTATIONS

| 40 | . | 4 | . | 24DC | . | FCT | . | G |

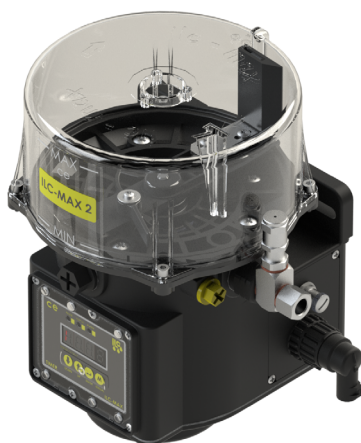

A (Reservoir)

2	2 kg
4	4 kg
8	10 kg

D (Timer)

CT	with timer
ST	without timer
DT	with datalog

B (Voltage)

12DC	12 V DC
24DC	24 V DC

E (Lubricant)

G	Grease
O	Oil
S	Soft Grease

C (Pumping Element)

F	Fixed
R	Adjustable
X	No element

Dimensions

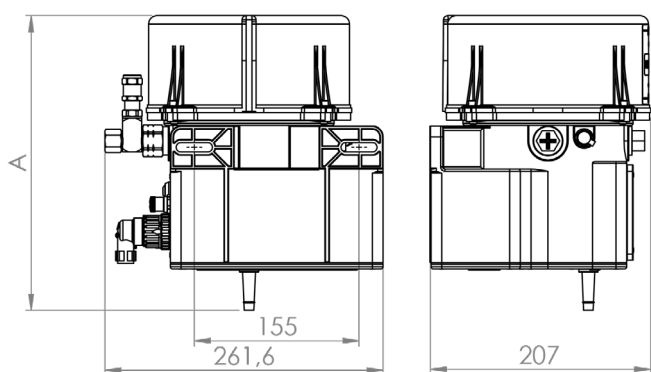

Cables

Lenght	4 Poles	7 Poles
5 m	40.CBL.4.05	40.CBL.7.05
10 m	40.CBL.4.10	40.CBL.7.10
15 m	40.CBL.4.15	40.CBL.7.15

Outlet Fittings Ø 6 mm

FH.040.102	Elbow
FH.040.002	Straight

A (height)

2 kg	277,60 mm
4 kg	349,60 mm
10 kg	543,10 mm

Fixing Screws (order 2 of each one)

UNI5931-M8x30	Screw
UNI7473-M08	Nut
UNI1734-D08	Washer

ILC MAX 8-16 Kg

How to build the part number

Working in TIME and ROTATIONS

| 40 | . | 8B | . | 24DC | . | FCT | . | G |

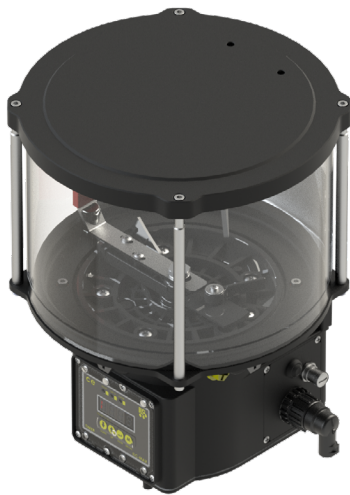

A (Reservoir)

8B	8 Kg
16	16 Kg

D (Timer)

CT	with timer
ST	without timer
DT	with datalog

B (Voltage)

12DC	12 V DC
24DC	24 V DC

E (Lubricant)

G	Grease
O	Oil
S	Soft Grease

C (Pumping Element)

F	Fixed
R	Adjustable
X	No element

Dimensions

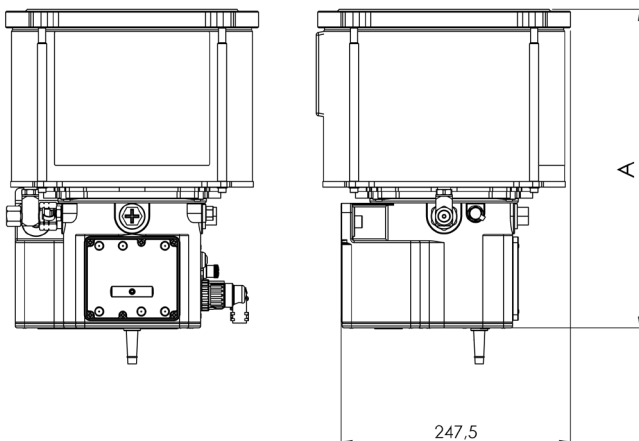

A (height)

8 Kg	344,1 mm
16 Kg	519,6 mm

Cables

Length

5 m	40.CBL.5.05.AK
10 m	40.CBL.5.10.AK
15 m	40.CBL.5.15.AK

5 Poles

Outlet Fittings Ø 6 mm

FH.040.102	Elbow
FH.040.002	Straight

Fixing Screws (order 2 of each one)

UNI5931-M8x30	Screw
UNI7473-M08	Nut
UNI1734-D08	Washer

MINI-MAX 3K

How to build the part number



| 3K | . | 12 | . | T X | . | F X | . | XXXXXXXX |



A (Voltage)		D (Metering Pump. Elem.)	
12	12 V DC	F	Fixed
24	24 V DC	R	Adjustable
		X	No Element

B (Timer)		E (Pumping elements)	
T	with timer	A	Metering 5 mm ³
X	without timer	B	Metering 10 mm ³
		C	Metering 15 mm ³

C (Electrical level)		D (Metering Pump. Elem.)	
L	with level	E	Metering 25 mm ³
X	without level	X	Metering 50 mm ³
		X	No Element

Dimensions

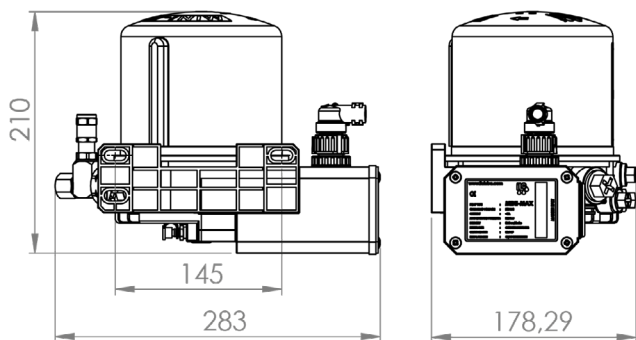

Cables

Length	5 Poles
5 m	40.CBL.5.05.AK
10 m	40.CBL.5.10.AK
15 m	40.CBL.5.15.AK

Outlet Fittings Ø 6 mm

FH.040.102	Elbow
FH.040.002	Straight

Fixing Screws (order 2 of each one)

UNI5931-M8x30	Screw
UNI7473-M08	Nut
UNI1734-D08	Washer

MINI-MAX

How to build the part number



| 39 | . | 12 | . | T | L | . | F R | . | AAAAAAAAAA |

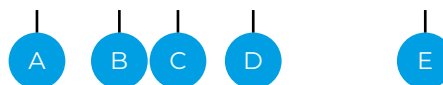

A (Voltage)		D (Metering Pump. Elem.)	
12	12 V DC	F	Fixed
24	24 V DC	R	Adjustable
		X	No Element

B (Timer)		E (Pumping elements)	
T	with timer	A	Metering 5 mm ³
X	without timer	B	Metering 10 mm ³
		C	Metering 15 mm ³
		D	Metering 25 mm ³
		E	Metering 50 mm ³
		X	No Element

C (Electrical level)	
L	with level
X	without level

Dimensions

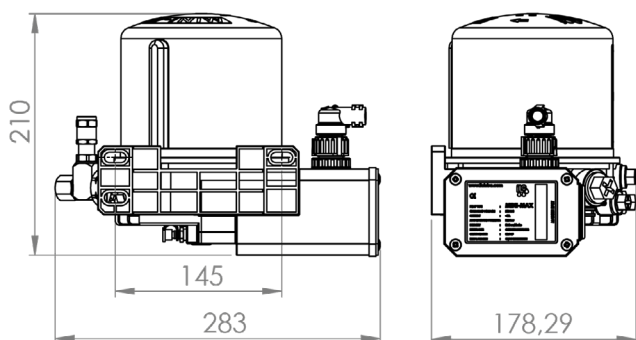

Cables

Length	5 Poles
5 m	40.CBL.5.05
10 m	40.CBL.5.10
15 m	40.CBL.5.15

Outlet Fittings Ø 6 mm

FH.040.102	Elbow
FH.040.002	Straight

Fixing Screws (order 2 of each one)

UNI5931-M8x30	Screw
UNI7473-M08	Nut
UNI1734-D08	Washer

45.12-24.DC.CT

45.12-24.DC.PG.CT



Dimensions

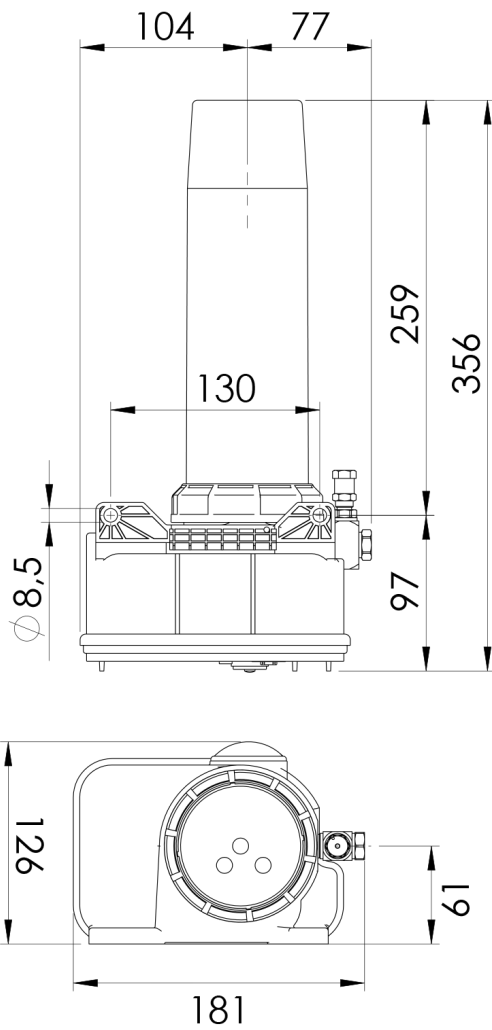

Four-wire connector

Length	Part n°
5 m	45.CDL.4.05
10 m	45.CDL.4.10

Inductive control Cable

Length	M12 (M)/M8X1 (F)	M12 (M)/M12 (F)
5 m	45.CDC.3.05	45.CDC.4.05
10 m	45.CDC.3.10	45.CDC.4.10

Cartridge Adaptor

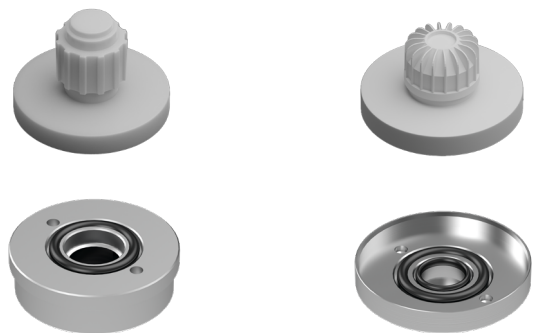

Ritter (400gr)	Reiner (500 gr)
A70.0931077	A70.0931078

The pump is supplied to accommodate a type "S" Shutter cartridge.

A70.093526 (300 μ - 1/4 "G seat)

07.270.7 (250 μ - pumping element seat)

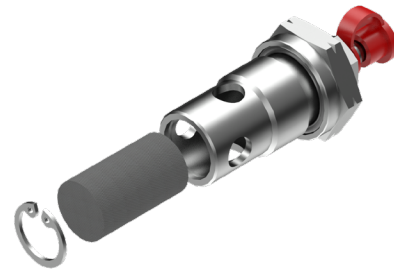

Complete filter Unit	A70.093526
Replacement Cartridge	93.086020
Filter	07.270.0
Banjo	A70.093596

Complete filter Unit	07.270.7
Replacement Cartridge	A93.086020

Manual loading pump and adapter (Grease)

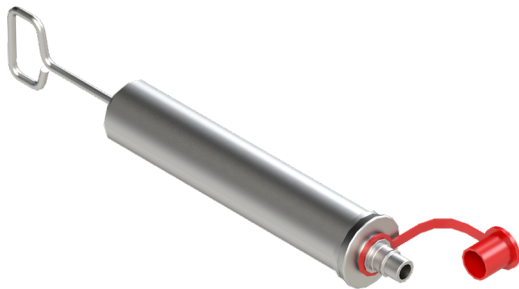

Manual pump	ZZZ100-201
-------------	------------

Adapter M22x1,5 with check valve	07.270.9
----------------------------------	----------

A51.1061003 (Elbow Extension M22x1,5)

Mini-Max filling nipple

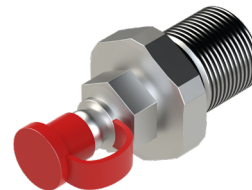

Load Extension	A51.1061003
----------------	-------------

Mini-Max filling nipple (same position of small PE)	A70.0931199
---	-------------

DPX M10

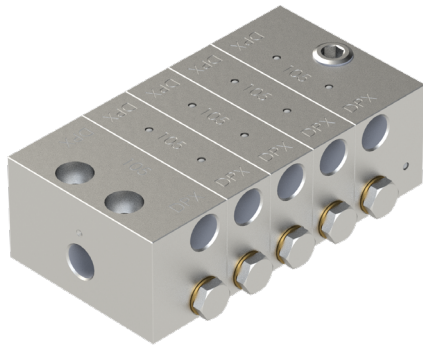

Segments

Tie Rods	N° of Elements	Length (mm)
2.TR.03	3	45
2.TR.04	4	60
2.TR.05	5	75
2.TR.06	6	90
2.TR.07	7	105
2.TR.08	8	120
2.TR.09	9	135
2.TR.10	10	150
2.TR.11	11	165
2.TR.12	12	180

Metering Elements

Discharge	Inlet	Intermediate	End
25 mm ³	2.A.025.D.1N.M10	2.B.025.D.1N	2.C.025.D.1N.M10
45 mm ³	2.A.045.D.1N.M10	2.B.045.D.1N	2.C.045.D.1N.M10
75 mm ³	2.A.075.D.1N.M10	2.B.075.D.1N	2.C.075.D.1N.M10
105 mm ³	2.A.105.D.1N.M10	2.B.105.D.1N	2.C.105.D.1N.M10

Metering Elements with Visual Pin

Discharge	Inlet	Intermediate	End
45 mm ³	2.A.045.D.2V.M10	2.B.045.D.2V	2.C.045.D.2V.M10
75 mm ³	2.A.075.D.2V.M10	2.B.075.D.2V	2.C.075.D.2V.M10
105 mm ³	2.A.105.D.2V.M10	2.B.105.D.2V	2.C.105.D.2V.M10

Dimensions

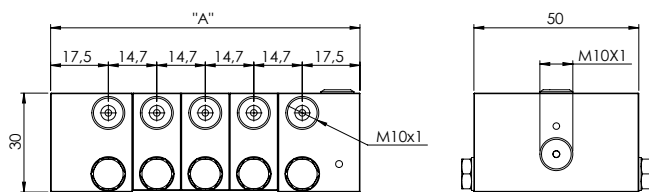

Ingresso M10x1

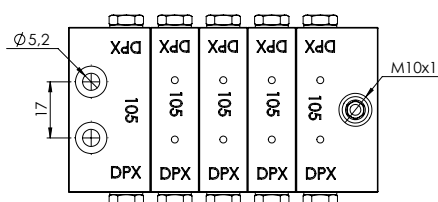

Cables

Length	M8x1 Straight	M12x1 Elbow	M12x1 Straight
5 m	A91.111227	A91.111441	A91.111349
10 m	A91.111348	A91.111552	A91.111296
15 m	A91.111393	A91.111318	A91.111350

Sensor Kit (PNP NA)

With Cable (2 m)	49.052.5
M8 x 1	49.052.7
M12 x 1	49.052.9

Fixing Screws (order 2 of each one)

UNI5931-M5x40	Screw
UNI7473-M05	Nut
UNI8842A-D05	Washer

DPX

Segments



Tie Rods	N° of Elements	Length (mm)
2.TR.03	3	45
2.TR.04	4	60
2.TR.05	5	75
2.TR.06	6	90
2.TR.07	7	105
2.TR.08	8	120
2.TR.09	9	135
2.TR.10	10	150
2.TR.11	11	165
2.TR.12	12	180

Metering Elements

Discharge	Inlet	Intermediate	End
25 mm ³	2.A.025.D.1N	2.B.025.D.1N	2.C.025.D.1N
45 mm ³	2.A.045.D.1N	2.B.045.D.1N	2.C.045.D.1N
75 mm ³	2.A.075.D.1N	2.B.075.D.1N	2.C.075.D.1N
105 mm ³	2.A.105.D.1N	2.B.105.D.1N	2.C.105.D.1N

Metering Elements with Visual Pin

Discharge	Inlet	Intermediate	End
45 mm ³	2.A.045.D.2V	2.B.045.D.2V	2.C.045.D.2V
75 mm ³	2.A.075.D.2V	2.B.075.D.2V	2.C.075.D.2V
105 mm ³	2.A.105.D.2V	2.B.105.D.2V	2.C.105.D.2V

Dimensions

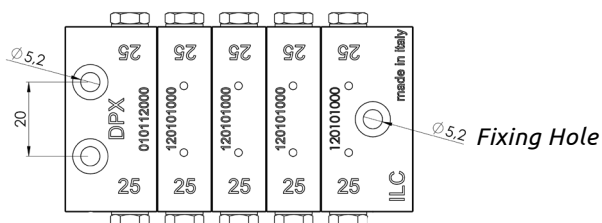
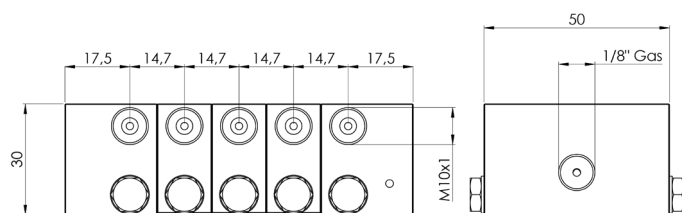

Cables

Length	M8x1 Straight	M12x1 Elbow	M12x1 Straight
5 m	A91.111227	A91.111441	A91.111349
10 m	A91.111348	A91.111552	A91.111296
15 m	A91.111393	A91.111318	A91.111350

Sensor Kit (PNP NA)

With Cable (2 m)	49.052.5
M8 x 1	49.052.7
M12 x 1	49.052.9

Fixing Screws (order 2 of each one)

UNI5931-M5x40	Screw
UNI7473-M05	Nut
UNI8842A-D05	Washer

DPL

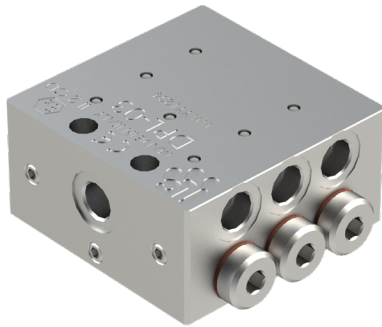

Outlets	Standard	Visual Pin
6	4.1N.03	4.2V.03
8	4.1N.04	4.2V.04
10	4.1N.05	4.2V.05
12	4.1N.06	4.2V.06
14	4.1N.07	4.2V.07
16	4.1N.08	4.2V.08
18	4.1N.09	4.2V.09
20	4.1N.10	4.2V.10

Complete of Inductive Sensor

Outlets	M8x1	M12x1
6	4.3I.8.03	4.3I.12.03
8	4.3I.8.04	4.3I.12.04
10	4.3I.8.05	4.3I.12.05
12	4.3I.8.06	4.3I.12.06
14	4.3I.8.07	4.3I.12.07
16	4.3I.8.08	4.3I.12.08
18	4.3I.8.09	4.3I.12.09
20	4.3I.8.10	4.3I.12.10

Dimensions

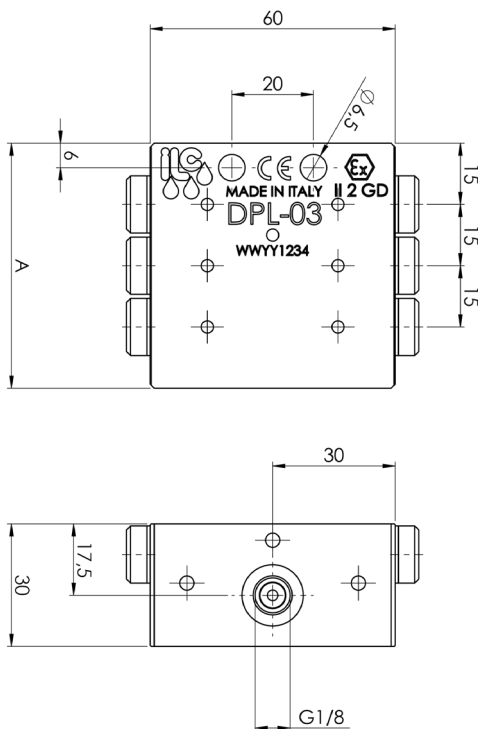

Cables

Length	M8x1 Straight	M12x1 Elbow	M12x1 Straight
5 m	A91.111227	A91.111441	A91.111349
10 m	A91.111348	A91.111552	A91.111296
15 m	A91.111393	A91.111318	A91.111350

Sensor Kit (PNP NA)

With Cable (2 m)	49.052.5
M8 x 1	49.052.7
M12 x 1	49.052.9

Fixing Screws (order 2 of each one)

UNI5931-M6x40	Screw
UNI7473-M06	Nut
UNI8842A-D06	Washer

ILC MAX Pumping Element



Fixed Discharge

90.900.0

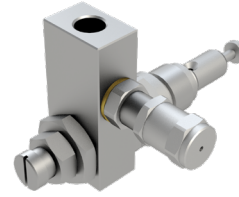

Adjustable Discharge

90.900.3



Fixed pumping element with 90° Outlet

90.902.2

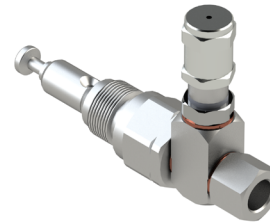

Fixed pumping element (Stem Ø8 mm)

90.900.0-D8

Minimax Pumping Element



Fixed Discharge

00.900.0

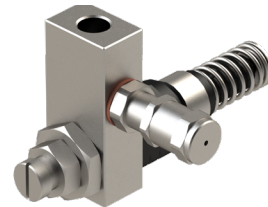

Adjustable Discharge

00.900.3

Minimax Small Pumping Element



Part N.	Discharge
90.940.0.05	5 mm ³
90.940.0.10	10 mm ³
90.940.0.15	15 mm ³
90.940.0.25	25 mm ³
90.940.0.50	50 mm ³

40.BMI.00



40.BMI.01



	Complete unit	40.BMI.00
1	Cap	A92.087.057
2	Pressure gauge 0-400 bar	46.600.0

	Complete unit	40.BMI.01
1	1/4" grease nipple	A70.078452
2	Pressure gauge 0-400 bar	46.600.0
3	Cap	A92.087.057

40.BMI.02



	Complete unit	40.BMI.02
1	1/4" grease nipple	A70.078452
2	Max pressure valve	A68.075011
3	Pressure gauge 0-400 bar	46.600.0
4	Cap	A92.087.057

Inlet / Outlet Fittings



Inlet				Outlet			
Straight	Elbow	Tube Ø 6	Divider	With Check Valve	No Check Valve	Tube Ø 6	Divider
FH.040.001	FH.040.101	1/8" BSP	DPX/DPL	FH.040.201	FH.040.006	M10x1	DPX
FH.040.006	FH.040.106	M10x1	DPX	14.052.0	03.222.1.06	M10x1	DPL



Nut and Sleeve Fittings (M10x1)	
Nut	Sleeve
04.052.0	06.052.0

Push-In Fittings



Inlet				Outlet			
Straight	Elbow	Tube Ø 6	Divider	Straight	Elbow	Tube Ø 6	Divider
03.256.0	03.256.6	1/8" BSP	DPX/DPL	03.256.3	03.256.7	M10x1	DPX
03.256.3	03.256.7	M10x1	DPX				

Push-In Fittings with check valve



Inlet				Outlet			
Straight	Elbow	Tube Ø 6	Divider	Straight	Elbow	Tube Ø 6	Divider
03.256.0.CVI	03.256.6.CVI	1/8" BSP	DPX/DPL	03.256.3.CV0	03.256.7.CV0	M10x1	DPX
03.256.3.CVI	03.256.7.CVI	M10x1	DPX				

Check Valves



Inlet			Outlet		
Check Valve	Thread	Divider	Check Valve	Thread	Divider
14.050.3	1/8" BSP	DPX/DPL	14.050.8	M10x1 (F)	DPX
14.050.4	M10x1 (F)	DPX	03.222.2.CV	M10x1 (F)	DPL

Divider Accessories

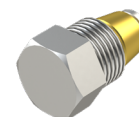
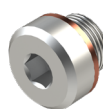

DPX Plug		DPL Plug	
Part N.	Thread	Next Outlet Plug	Other Side Plug
A70.093229	M10x1	05.026.1	05.026.0

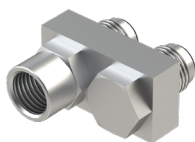
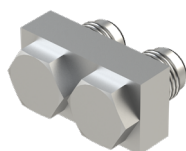

DPX Bridges		Banjo		
Without Outlet	With Outlet	Part N.	Thread	Divider
09.600.3.R	09.600.4.R	03.355.5	1/8" BSP	DPX/DPL
		03.355.6	M10x1	



DPX Bridge junction
09.600.8

Hose fittings



Sleeve			Stud 45°		
Part N.	L	Key	Part N.	L	Key
FH.020.001		SW12	FH.030.202	25 mm	SW10



Stud Straight			Stud Elbow		
Part N.	L	Key	Part N.	L	Key
FH.030.002	30 mm	SW10	FH.030.101	37 mm	SW10

Hoses

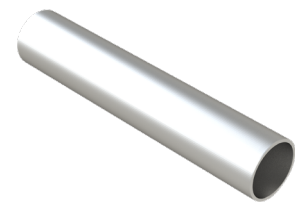
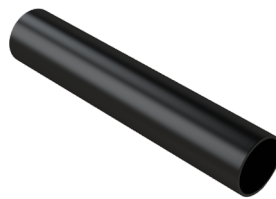

High Pressure 8.6 x 4 mm (min. 100 m)		Polyamide PA12 6 x 3 mm (min. 100 m)		Steel Tube (6 m)	
Part N.	Grease	Part N.	Grease	Part N.	Ø
FH.010.002	NLGI2 Full	30.155.3.NP	NLGI2 Full	ZZZTC6/4/1	Ø 6 mm
FH.010.001	Empty	30.155.3.N	Empty	ZZZTC10/5/2.5	Ø 10 mm

Protections



Helix Protection (min. 50 m)		Flexible Conduit (min. 50 m)		Metallic Protection (6 m)	
ZZZ100-040	Ø 6 mm	A91.111521	Ø 6.9 mm	ZZZ00208210	Ø 6 mm
ZZZ100-041	Ø 11.5 mm				

Clamps and Straps

Connectors

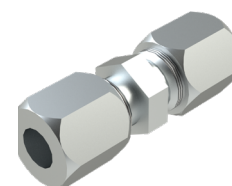

Hose Clamps		Hose Strap		Hose-Hose Connector	
Part N.	Size	Part N.	Length	Part N.	Thread
ZZZ100-606	Ø 6 mm	A91.111273	380 mm	FH.050.001	Ø 6 mm
ZZZ100-608	Ø 8 mm	A91.111274	200 mm	ZZZ106-000-10-L	Ø 6 mm - 10 mm
ZZZ100-610	Ø 10 mm				
ZZZ100-612	Ø 12 mm				
08.609.1	Ø 14 mm				
08.609.2	Ø 16 mm				
ZZZ100-618	Ø 18 mm				
ZZZ100-620	Ø 20 mm				
Fixing					
UNI5931-M6x20	Screw				
UNI1734-D06	Washer				
UNI7473-M06	Nut				

Point Fittings

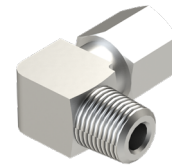
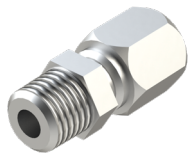

Straight		Tube Ø 6	Elbow		Tube Ø 6
FH.040.003		M6x1	FH.040.103		M6x1
FH.040.004		M8x1	FH.040.104		M8x1
FH.040.006		M10x1	FH.040.106		M10x1
FH.040.001		1/8"	FH.040.101		1/8"
FH.040.002		1/4"	FH.040.102		1/4"

45° Adapter M-F

Elbow Adapter M-F

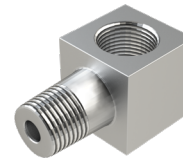
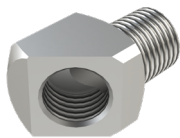

ZZZ100-822	M8x1 - M8x1	ZZZ100-721	M6x1 - M8x1
ZZZ100-833	M10x1 - M10x1	ZZZ100-722	M8x1 - M8x1
ZZZ100-844	1/8" - 1/8"	ZZZ100-723	M10x1 - M8x1
		ZZZ100-724	1/8" - M8x1
		ZZZ100-733	M10x1 - M10x1
		ZZZ100-744	1/8" - 1/8"

Extension Pieces M-F

Straight Adaptor R 1/8 - G 1/8 F (h=60 mm)



ZZZ100-130	M8x1-M8x1	18 mm	Part n° 03.205.2
ZZZ100-137	M8x1-M10x1	23 mm	
ZZZ100-140	M10x1-M8x1	18 mm	
ZZZ100-141	M10x1-M10x1	23 mm	
ZZZ100-142	M10x1-M10x1	18 mm	
ZZZ100-143	M10x1-M10x1	40 mm	
ZZZ100-145	M10x1-M10x1	35 mm	
ZZZ100-146	M10x1-M10x1	50 mm	
ZZZ100-148	1/8" - 1/8"	23 mm	
ZZZ100-149	1/8" - 1/8"	35 mm	
ZZZ100-151	1/8" - M10x1	18 mm	
ZZZ100-152	1/8" - 1/8"	18 mm	
ZZZ100-153	1/8" - 1/8"	50 mm	

Greasing Block 1/8"



Greasing Block M10x1

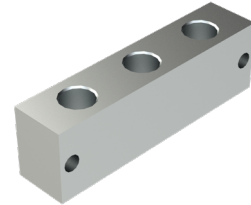

Part N.	Outlets
01.110.1	1
01.110.2	2
01.110.3	3
01.110.4	4
01.110.5	5
01.110.6	6
01.110.7	7
01.110.8	8

Part N.	Outlets
ZZZ100-210-1	1
ZZZ100-210-2	2
ZZZ5029-103	3

Elbow Greasing Block 1/8"

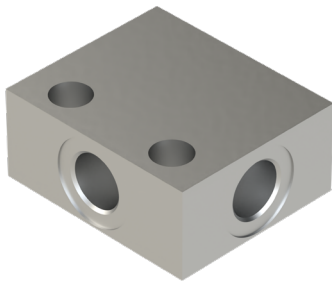

01.151.1

Elbow Greasing Block M10x1

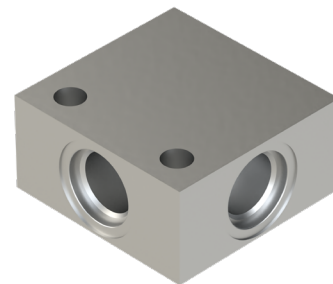

01.831.5

Cabine Push Button



External Timer (12-24 V DC)



Part N.

Voltage

40.BCT.BT.DC

40.PSG.12

12 V DC

40.PSG.24

24 V DC

Grease Nipples



Welding Protection

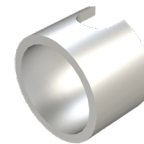

Straight

Thread

08.111.0

A70.078422

1/8" BSP

A70.078440

M10x1

A70.078452

1/4" BSP

Dpx Bracket



A51.120002

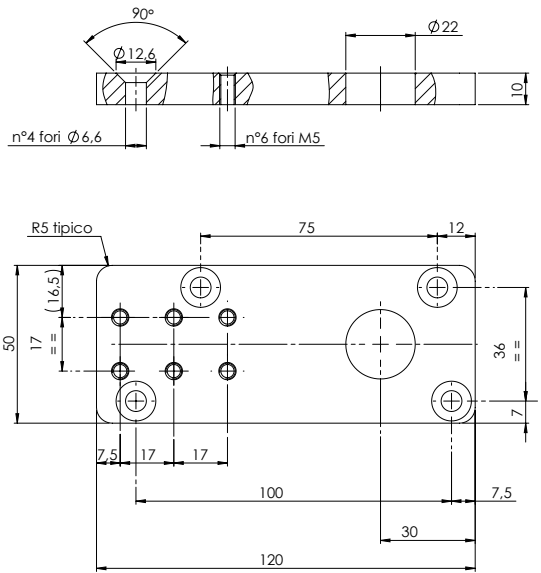

Z Bracket

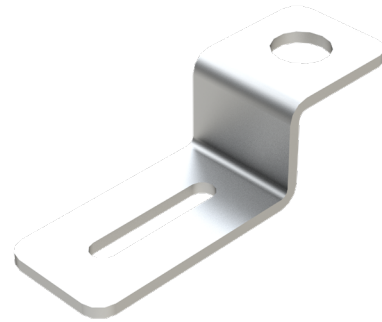

08.112.0

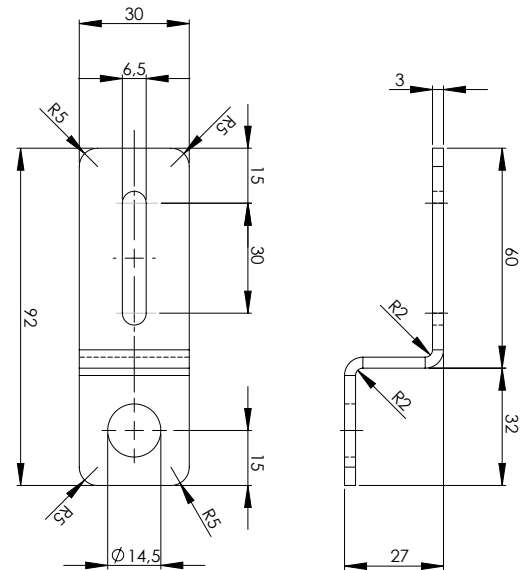

Pump Bracket

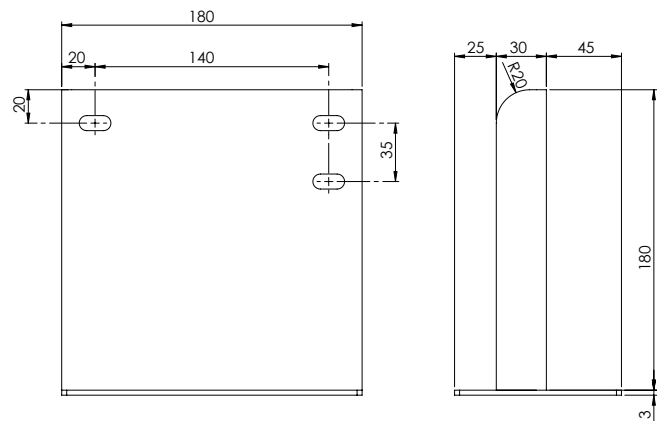

A51.120001

Hydra

How to build the Part Number



| 86 | . | 27 | . | 1 | . | 1 | . | X | . | X | . | X |

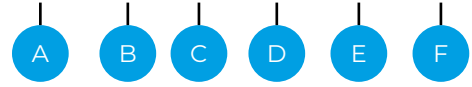

A (Pump)		B (Release Module)	
27 Kg	27	Yes	1
41 Kg	41	No	X
180 Kg	18	Valve Only	2
C (Tank)		D (Presser Disc)	
Cover Only	1	Yes	1
Complete Tank	2	No	X
Without Tank	X		
E (Level Sensor)		F (Loading Kit)	
Yes	1	Yes	1
No	X	No	X

Dimensions

Kg	A (mm)	B (mm)	C (mm)	D (mm)
27	430	578	811	508
41	646	794	1027	724

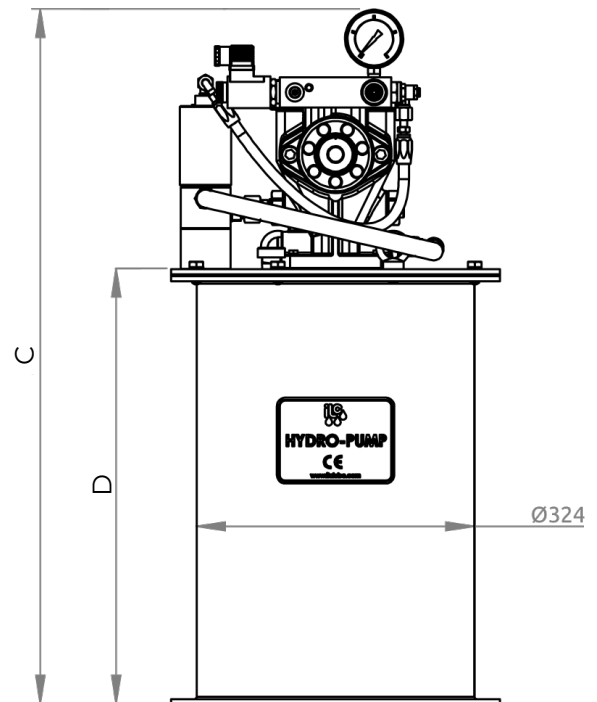
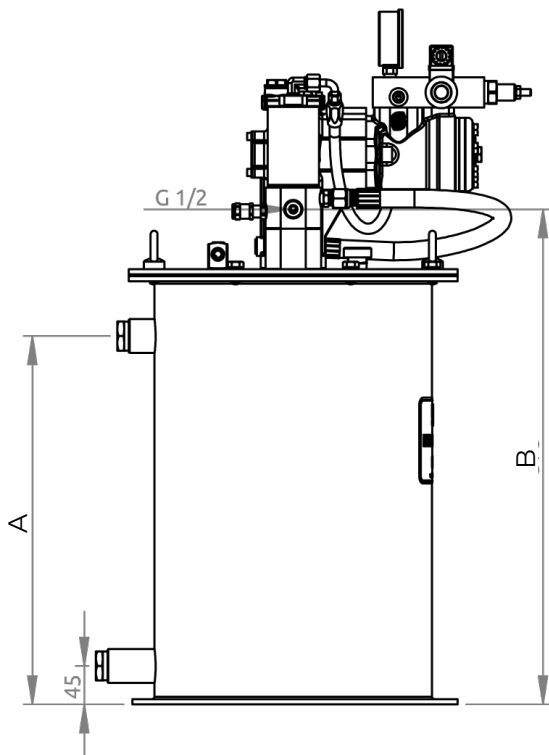

Elektra

How to build the Part Number



| 87 | . | 27 | . | 1 | . | 1 | . | X | . | X | . | X | . | X |



A (Pump)		B (Release Module)	
27 Kg	27	Yes	1
41 Kg	41	No	X
180 Kg	18	Valve Only	2

C (Tank)		D (Presser Disc)	
Cover Only	1	Yes	1
Complete Tank	2	No	X
Without Tank	X		

E (Level Sensor)		F (Loading Kit)	
Yes	1	Yes	1
No	X	No	X

G (motor)					
Three-phase			Single-phase		
230/ 400V 50 Hz - 280/ 480V 60 Hz	S	575 V 60 Hz	D	115 V AC 60 Hz	B
460 V 60 Hz	H	500 V 50 Hz	E	230 V AC 50 Hz	C
380 V 60 Hz	F	550 V 50 Hz	G	24 V DC	X

Dimensions				
Kg	A (mm)	B (mm)	C (mm)	D (mm)
27	733	508	430	580
41	949	724	646	796

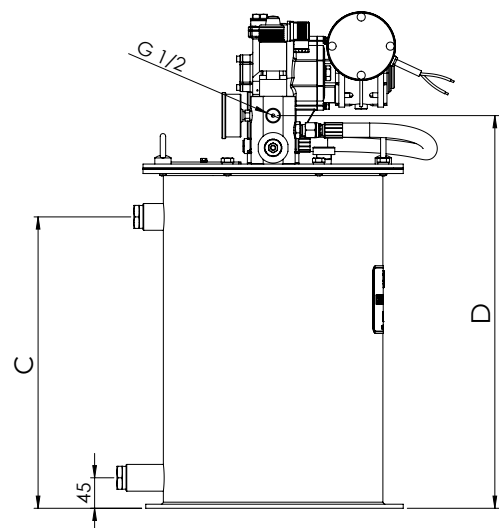
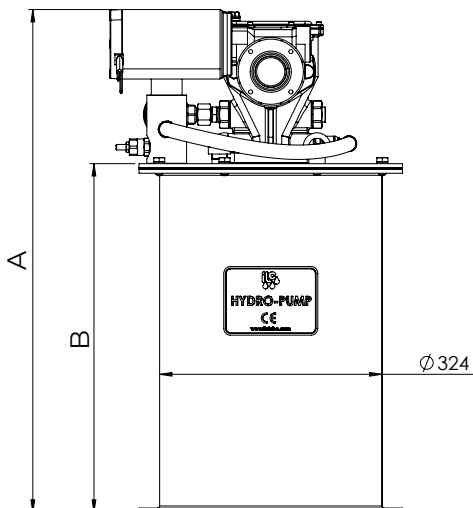

CX-1

Injectors

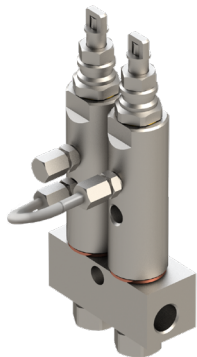
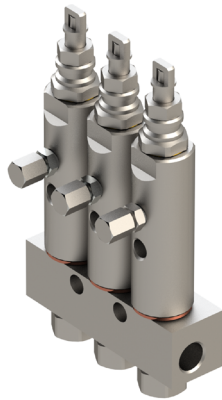

Single Injector

Oil	Grease
02.940.1.O	02.940.1.G

Injectors+Block

Oil	Grease	Outputs
02.940.1.O.01	02.940.1.G.01	1
02.940.1.O.02	02.940.1.G.02	2
02.940.1.O.03	02.940.1.G.03	3
02.940.1.O.04	02.940.1.G.04	4
02.940.1.O.05	02.940.1.G.05	5
02.940.1.O.06	02.940.1.G.06	6

Blocks

Part no.	Outputs
01.190.1	1
01.190.2	2
01.190.3	3
01.190.4	4
01.190.5	5
01.190.6	6

Two outputs can be joined with the bridge joint on request.
09.600.6: in this case, the two outputs of the CX-1 valves will add up.

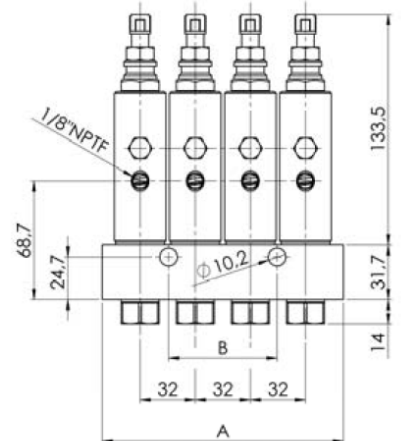
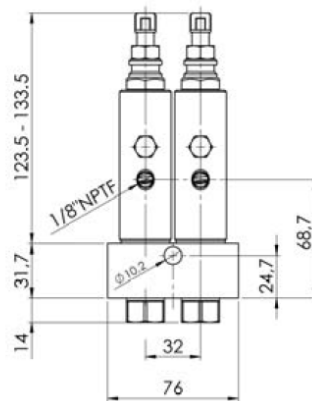
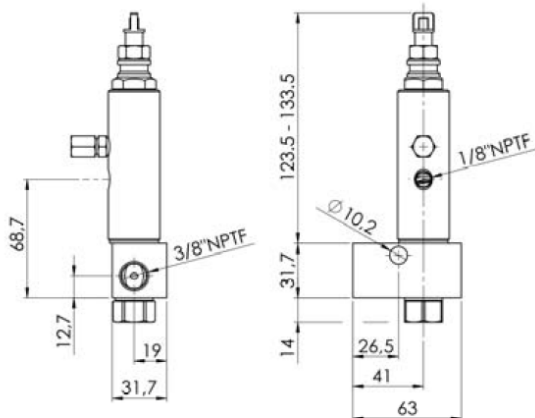

Fittings

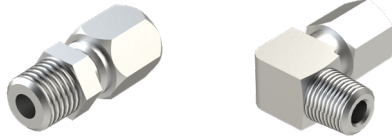

External Timer



Straight	Elbow	Tube Ø 6	86.BCT.24V.DC		
FH.040.001	FH.040.101	1/8" BSP			

Hose fittings



Sleeve			Stud 45°		
Straight		Key	Part N.	L	Key
FH.020.001		SW12	FH.030.202	24 mm	SW10



Stud Straight			Stud Elbow		
Part N.	L	Key	Part N.	L	Key
FH.030.001	20 mm	SW10	FH.030.101	37 mm	SW10
FH.030.002	30 mm	SW10	FH.030.102	53 mm	SW10

PMU Pump



Ratio 16:1	Ratio 8:1	Outlets
00.660.02	00.660.102	2
00.660.04	00.660.104	4
00.660.06	00.660.106	6
00.660.08	00.660.108	8
00.660.10	00.660.110	10
00.660.12	00.660.112	12

Transmission Kit

Reservoir (4L)

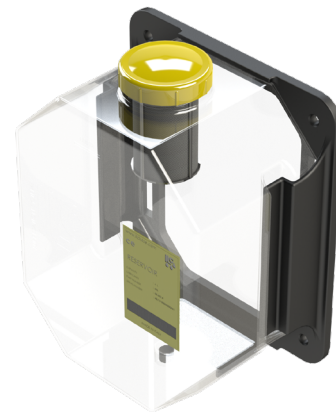

00.665.2

00.652.5

High Pressure Fittings



Straight M8x1		Elbow M8x1	
Part N.	Tube Ø	Part N.	Tube Ø
03.255.2	4	03.255.6	4
03.256.2	6	03.257.1	6

Low Pressure Fittings



Straight			Elbow			"Y"	
Part N.	Tube Ø	Thread	Part N.	Tube Ø	Thread	Part N.	Tube Ø
A92.106074	8	1/8" G	A92.106110	8	1/8" G	A92.106454	4
A92.106113	6	1/8" G	A92.106195	6	1/8" G	A92.106455	6
A92.106123	8	1/4" G	A92.106218	4	1/8" G		
A92.106133	6	1/4" G	A92.106224	6	1/4" G		
A92.106165	4	1/8" G	A92.106248	8	1/4" G		

Brushes

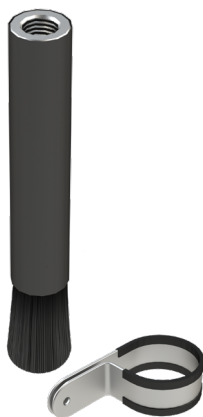

0.2 mm Nylon Brush / Steel body			0.2 mm Nylon Brush / Brass body			0.3 mm Nylon Brush / Aluminium body		
Part N.	Brush	Thread	Part N.	Brush	Thread	Part N.	Brush	Thread
14.000.8	Brush	1/8"	14.000.2	Brush	5/16"-24 UNF	14.001.2	Brush	1/8"
08.608.5	Clamp	-						

I.L.C. srl - Via Garibaldi, 149 - 20155 Gorla Minore - Italy
Phone +39 0331 601697 - Fax +39 0331 602001 - www.ilclube.com - info@ilclube.it

